

# Turbocharger Instructions

## ^ Table of contents

### ▾ Recommendations

#### ▾ Kit Contents

#### ▾ Tools Required

#### ▾ SUGGESTED LUBRICANTS AND SEALANTS

### ▾ **TURBOCHARGER OVERVIEW**

#### ▾ **FITTING YOUR TURBOCHARGER**

##### ▾ **M**

##### ▾ Fitting the Oil Lines

##### ▾ Fitting Compressor Intake Pipework

##### ▾ Fitting Water Lines (If fitted)

##### ▾ Confirmation of Turbocharger Clocking

##### ▾ Boost Control

#### ▾ TROUBLE SHOOTING

Product Name:

Turbocharger

Product Description: Oil Cooled / Water Cooled Instructions  
Product Number: TS-1/2

---

## **Important notes on your new Turbosmart Turbocharger**

- Turbosmart accepts no responsibility whatsoever for incorrect installation of this product which is potentially hazardous and can cause serious engine damage or personal injury
- Consult your local specialist before selecting your desired turbocharger, incorrect sizing may go beyond your engines capability and may result in engine damage.
- Consult your local specialist before setting your desired boost pressure, setting boost beyond your engines capability may result in engine damage.
- Use only high-quality fittings ensuring maximum sealing reliability. Optional Turbosmart fitting kit available.

## **Recommendations**

- Fitting your Turbosmart Turbocharger may require fabrication or modification to your exhaust manifold. Turbosmart recommends that your turbocharger is fitted by an appropriately qualified technician.
- Turbosmart recommends that the engines Air/Fuel ratio is checked while setting the desired boost pressure, as any increase in boost pressure can cause the engine to run “LEAN”, resulting in possible engine damage.
- Turbosmart recommends that boost pressure is set using a dynamometer and not on public roads.
- Ensure the oil is replaced, filters are clean and lines are free from obstruction or ingress of foreign bodies.
- New turbochargers may be delivered in a state that facilitates installation, housings should be inspected that all mounting bolts or V-Bands are correctly torqued.
- Oil drain should be within 35 degrees of the horizontal plane to allow for gravity to aid in oil flow in the return
- Turbosmart recommends that a boost gauge be permanently fitted to the vehicle.

## **ⓘ Kit Contents**

Part	Description	Use
1	Turbosmart Turbocharger	Main unit comes with V-Band clamps x 2 Weld flanges x 2 -4An Oil Feed Oil drain fitting  <b>No T series gaskets</b>
2	Oil Drain Gasket	
3	Instruction Card	
4	Turbosmart Sticker	Turbosmart Sticker

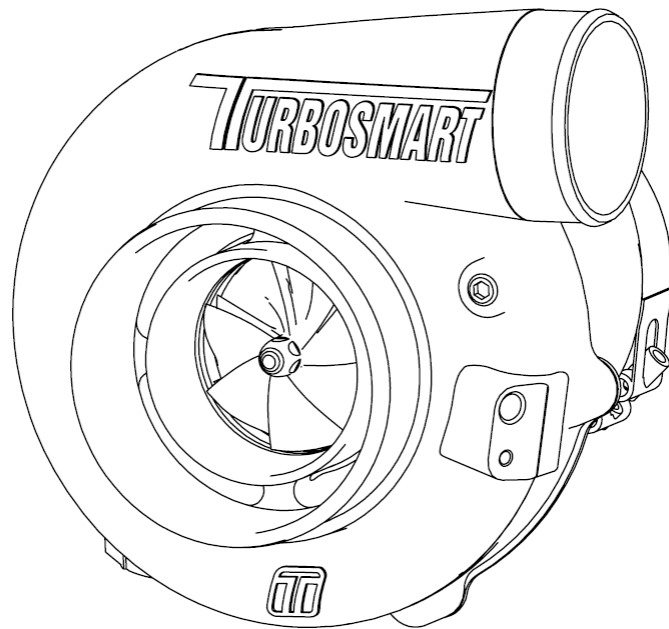

## ⓘ Tools Required

- General Automotive Tools

## 💡 SUGGESTED LUBRICANTS AND SEALANTS

- As specified by automotive manufacture

## TURBOCHARGER OVERVIEW

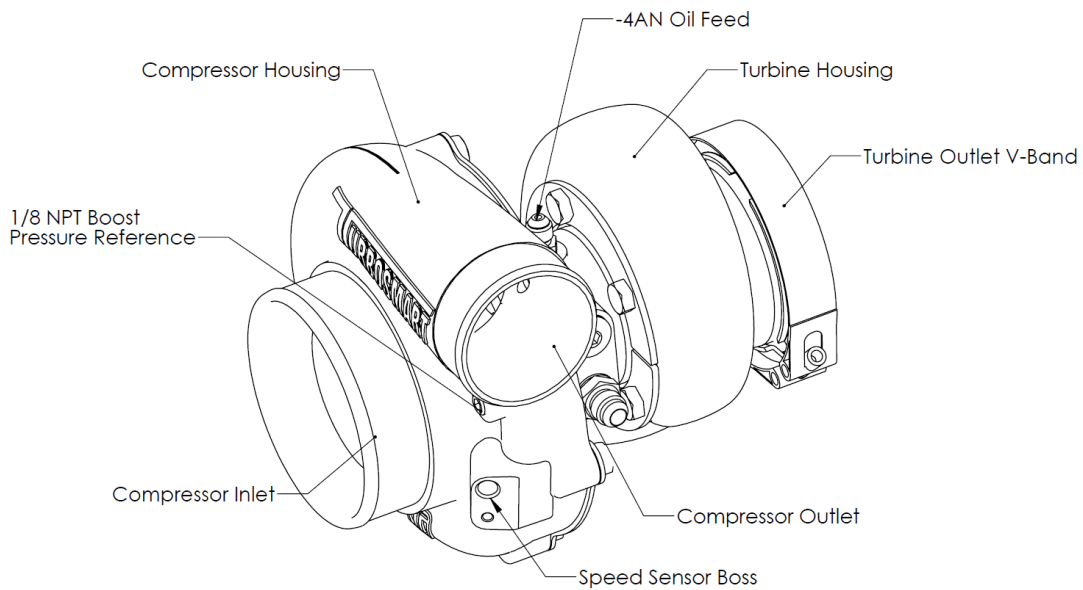

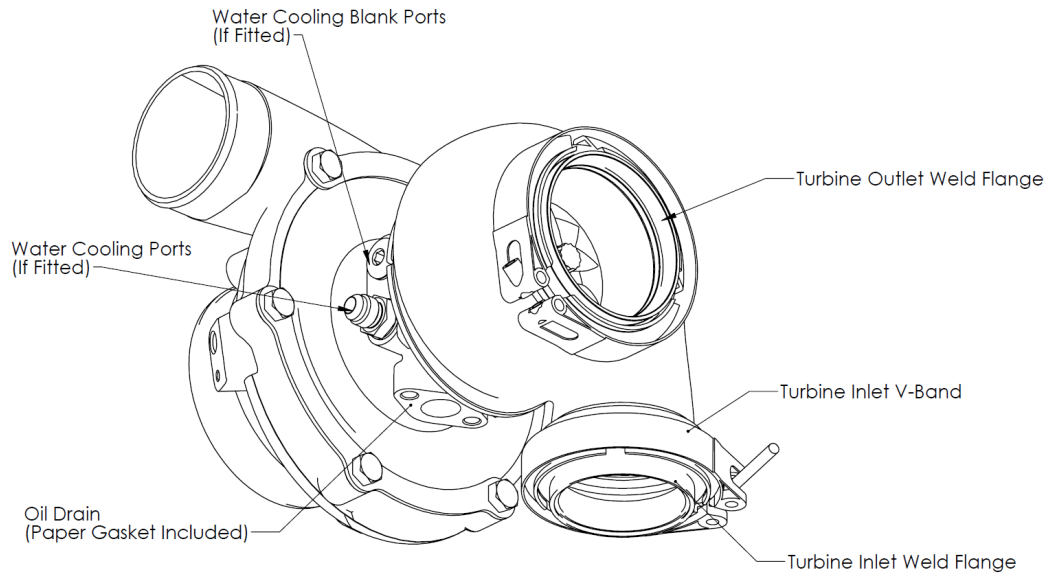

## FITTING YOUR TURBOCHARGER

### Mounting your new Turbosmart Turbocharger

There are 3 current mounting options these are T3, T4 Style flange and 3 inch V-Band. Ensuring that a gasket is used to mount the T3/4 Style flanges and the correct torque of the V-Bands 7N/m(5ft/lbs).

 Note: T3/4 Style flanges require a gasket for sealing between the exhaust manifold.

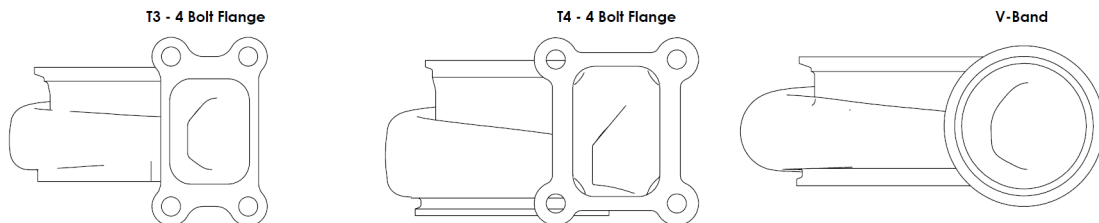

Place v-band clamp over weld on flange by unscrewing the nut on the v-band as far out as possible and then squeezing the bolt in a syringe motion to expand the v-band (squeeze the dots together below). Once the v-band is in its fully expanded position, slide the v-band over the flange to allow for the turbo to be installed. Using the 3/8" deep socket and a torque wrench tighten the V-Band to 7N.m (5 ft/lbs). Ensure the manifold is seated correctly while torquing the nut, failure to seat the flanges correctly before tightening the v-band clamp will cause an exhaust leak.

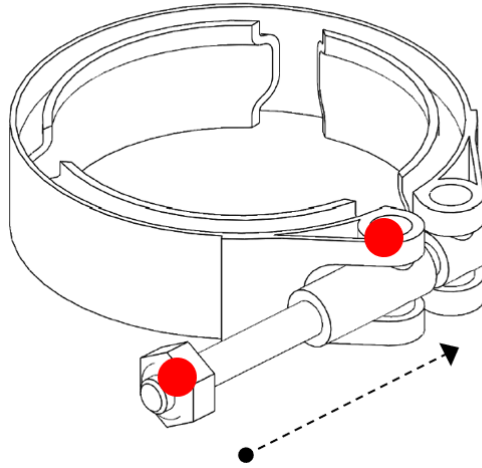

## Fitting the Oil Lines

With the turbine housing fitted, engine oil is required to be fed to the -4AN thread fitting on the top of the turbocharger from the engine's pressurised oiling system. Turbosmart recommends the installation of a turbocharger oil filter (part number [TS-0804-1002](#)) or for engines with particularly high oil pressure, a Turbosmart turbocharger oil pressure regulator (such as [TS-0811-0012](#)) is recommended.

 Note: Failure to inspect and clean oil lines will result in damage to the turbocharger.

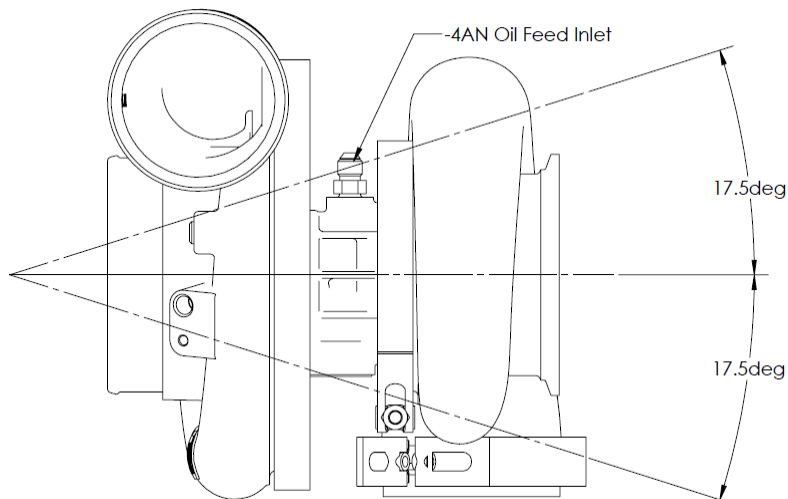

Turbocharger lubricating oil must also drain into the sump. A unrestricted path for the oil drain should be fed back into the sump of the engine. Correct oil drain flanges are available below. The oil drain has an acceptable limit of 35 deg to allow for correct drainage to the sump.

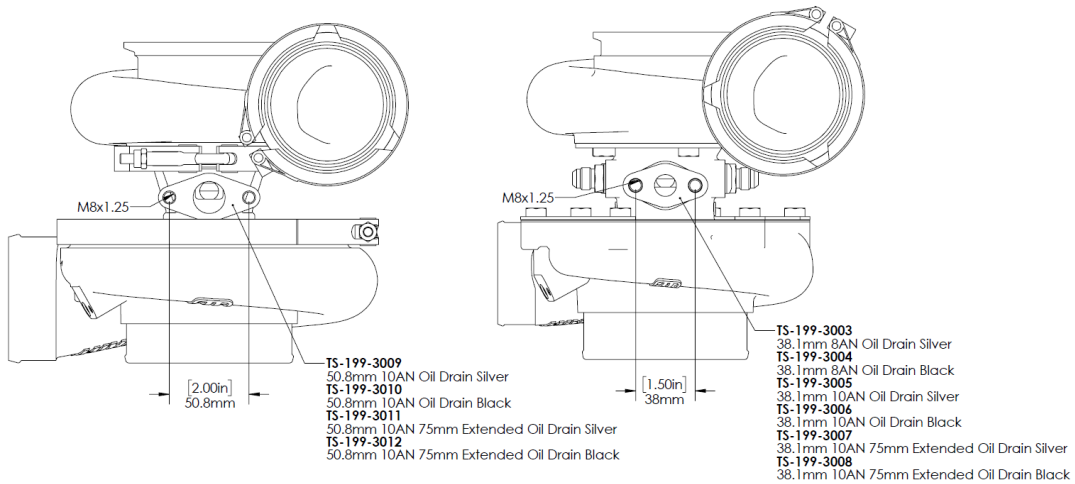
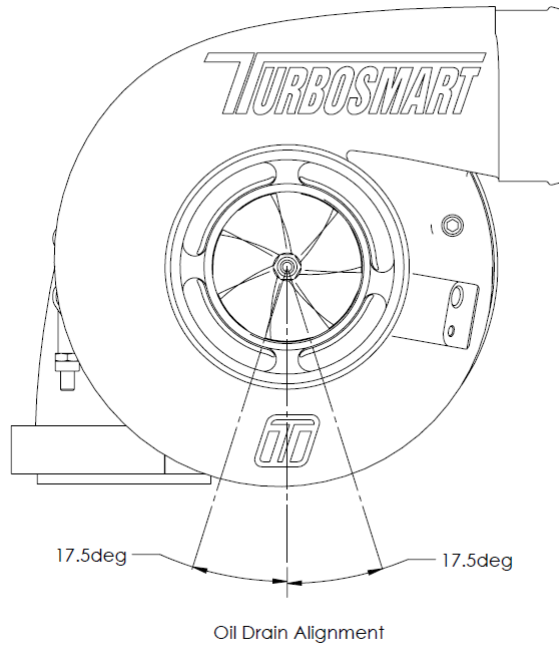

## Fitting Compressor Intake Pipework

Fitting the air intake pipework is generally a matter of sliding correctly sized silicone pipework onto the compressor cover. High quality hose clamps should be used to ensure a positive seal. It's recommended that a filter is used on the compressor inlet to stop foreign bodies from entering the turbocharger and causing serious damage.

## Fitting Water Lines (If fitted)

Water lines require a AN 6 style fitting to work, water lines should be taken from the cooling system, with hot water being fed into the lower to the horizontal port and fed out via the higher from the horizontal port, in an aid to promote thermal siphoning. The threads are a M14x1.5 thread. Port logic is non directional and the blanks could be swapped if the install required.

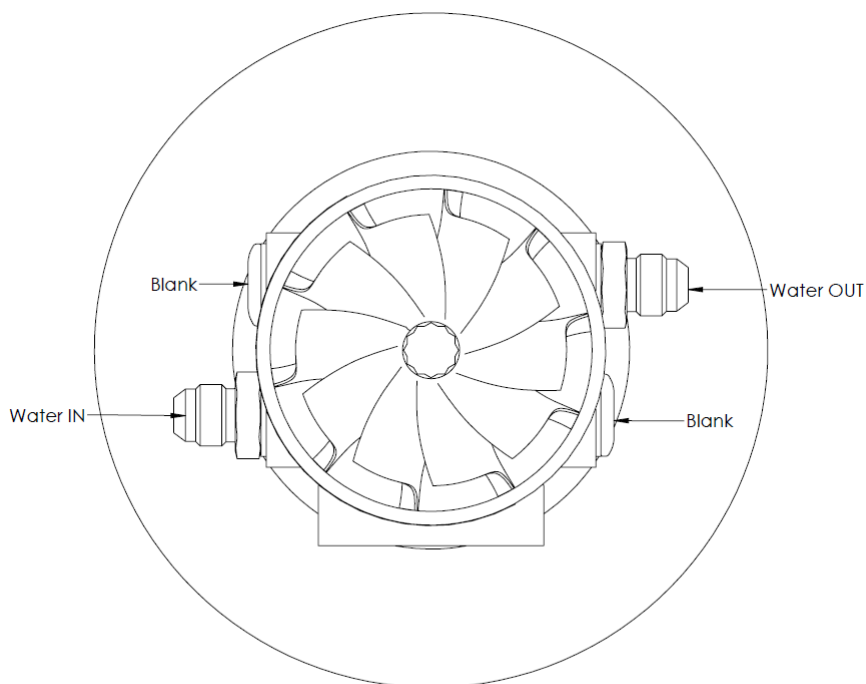

## Confirmation of Turbocharger Clocking

Once a final fitment has been confirmed, the water and oil lines installed without excess strain on them and the turbo is within the acceptable tilt angle for oil drain, the turbocharger should be inspected and all bolts tightened and checked for leaks.

 Note: Failure to verify that the turbocharger is torqued to spec can lead to serious damage.

## Boost Control

If no boost controller is being used, connect the boost pressure source to your Turbosmart wastegate actuator. Boost reference hose plumbing logic will depend on the product being used as well as the style of boost control. Consult your wastegate instructions, the most basic example has been provided below.

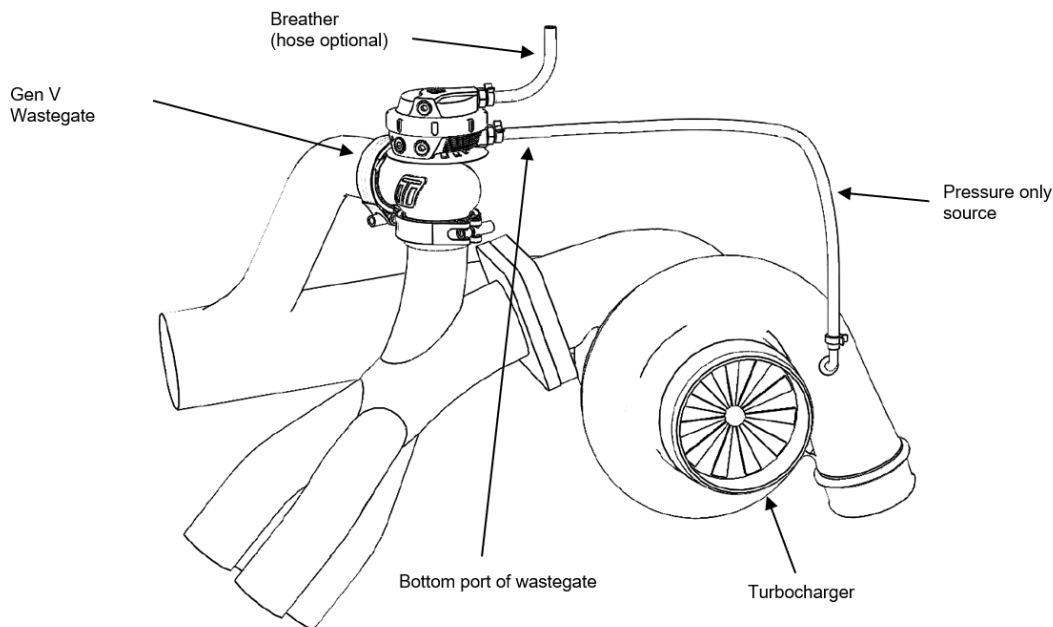

⚠ Caution! Do NOT source signal from the intake manifold as this is subject to vacuum and pressure losses across the system and could over-speed the turbocharger.

### Pre-lubrication of Turbocharger

It's essential to prefill the turbocharger with fresh engine oil and spin the turbo by hand to ensure adequate oil lubrication prior to the first engine startup. It is not uncommon to see long crank times to get the correct oil pressure.

📄 Note: It is good practice to idle the car for its first heat cycle and reconfirm all fasteners and fittings to ensure correct torque.

⚠ Caution! Make sure to reconnect the oil feed line before running the engine.

Start engine and check for leaks.

Congratulations, your Turbosmart Turbocharger is installed and ready for use. Double check all fittings, lines and mountings then proceed to start engine and check for leaks. Making sure to reconfirm the correct engine oil level as the system pressurises.

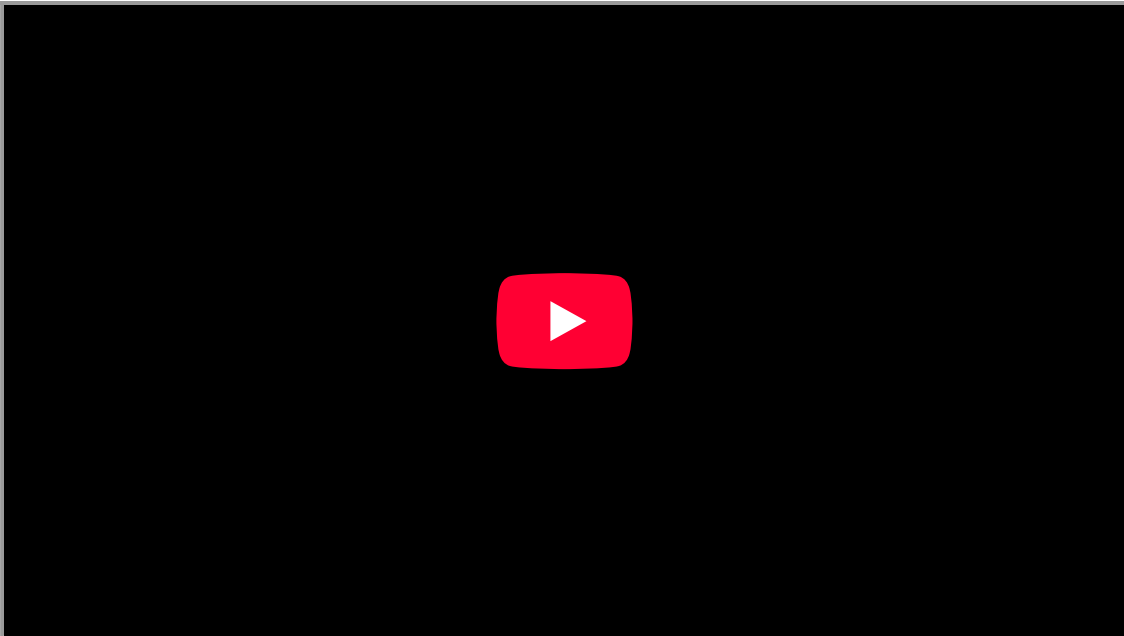

---

## **ⓘ TROUBLE SHOOTING**

- Insufficient power/boost pressure
  - Check for boost leaks
- Turbocharger makes abnormal noises
  - Check for exhaust leaks, gaskets are present.
  - Insufficient Oil supply
  - No BOV is present
- Excessive Smoke
  - Oil drain isn't draining as required.
  - Insufficient oil supply
  - Oversupply of oil
- Boost Pressure too high
  - Check for wastegate priority
  - Correct valve opening as to not cause boost creep
- Failing the above, submit a [technical request form](#) with information about your engine, oil type and photos of the installation and one of our expert technicians will respond as soon as possible.